

PC-1867F Ceiling Mount Fire Dome Speaker

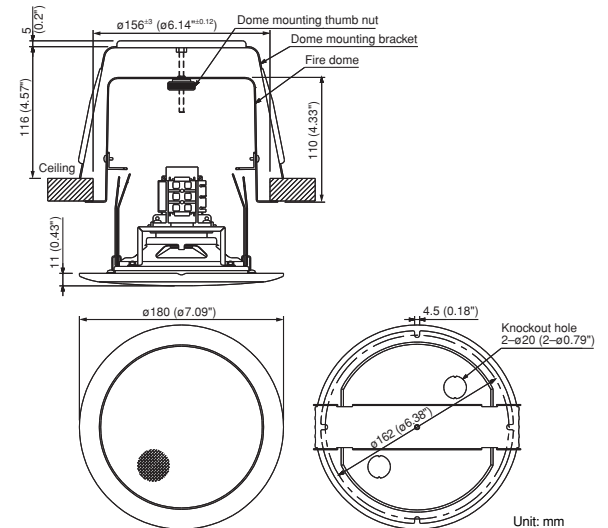

APPEARANCE AND DIMENSIONAL DIAGRAM



DESCRIPTION

TOA's PC-1867F Ceiling Mount Speaker features an iron-made dome that prevents the fire from spreading in the ceiling in case of an emergency situation. 12cm (5") cone-type speaker unit ensures high-quality sound. The speaker can be easily installed using the speaker mounting spring and the dome can also be easily mounted in the speaker mounting hole in the ceiling panel. The rated input is 6W for a 100V line and 3W for a 70V line. The PC-1867F comes with a push-in connector that permits one-touch cable connection as well as bridging and branch wiring.

FEATURES

- Flush-mount ceiling speaker with iron-made dome
- Fire-resistant front grille is finely meshed, enabling low speaker profile
- Easy installation with spring catches
- Full-range 12 cm (5") speaker
- High sensitivity: 90 dB (1W, 1m)
- Push-in connector for one-touch cable connection as well as bridging and branch wiring
- Ideally suited for voice alarm system application

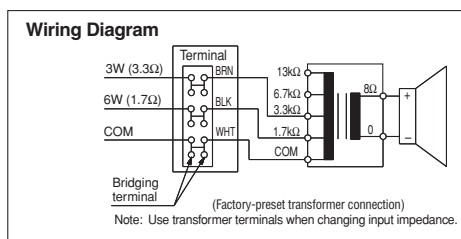

SPECIFICATIONS

Rated Input:	6 W (100 V Line), 3 W (70 V Line)
Rated Impedance:	100 V line: 1.7 kΩ (6 W), 3.3 kΩ (3 W) 6.7 kΩ (1.5 W), 13 kΩ (0.8 W) 70 V line: 1.7 kΩ (3 W), 3.3 kΩ (1.5 W) 6.7 kΩ (0.8 W), 13 kΩ (0.4 W)
Sensitivity (1W, 1m):	90 dB (330Hz – 3.3kHz, pink noise)
Frequency Response:	100Hz – 16kHz (without fire dome)
Speaker Component:	12 cm (5") cone-type
Dimensions for Fixing Hole:	ø156±0.15 (mounting hole) × 30 (maximum ceiling thickness) mm (ø6.14±0.12 × 1.18")
Speaker Mounting Method:	Spring catch
Applicable Cable:	Solid copper wire: ø0.8 – ø1.6 mm (AWG 20 – 14) 7-core twisted copper wire: 0.75 – 1.25mm ² (AWG 18 – 16)
Connction:	Push-in connector (Bridging terminal-2 branch type)
Finish:	Baffle: Aluminum, off-white (RAL 9010 or equivalent color), paint Grille: Aluminum net, off-white (RAL 9010 or equivalent color), paint Dome mounting bracket: Steel plate, trivalent chromate treatment plating Fire dome: Steel plate, black, painting
Dimensions:	ø180 × 11 (exposed section) + 110 (D) mm (ø7.09" × 0.43" + 4.33")
Weight:	1.4 kg (3.09 lb) (bracket, fire dome included)
Accessory:	Rubber grommet × 2, Paper pattern × 1



CHARACTERISTIC DIAGRAMS

SPL vs. Frequency

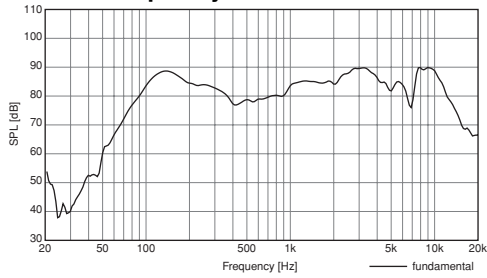

Beamwidth vs. Frequency

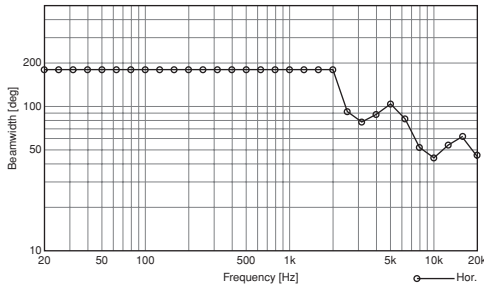

Directivity Factor vs. Frequency

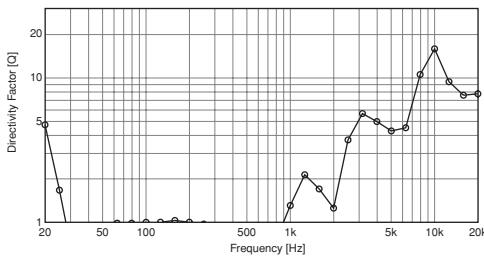

Polar Response

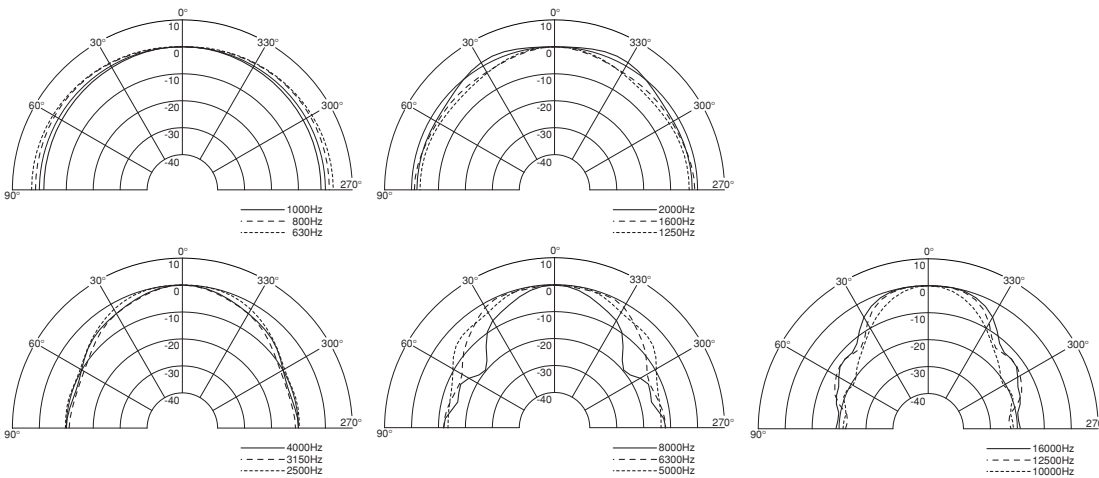

ARCHITECTURAL AND ENGINEERING SPECIFICATIONS

The ceiling speaker shall be a 12cm (5") cone-type, featuring a steel plate dome to prevent a fire from spreading in the ceiling during a fire emergency situation. The speaker shall be easily installed using its speaker mounting spring-catch, and the dome shall be easily mounted in the mounting hole of the speaker panel. Cable connection shall be by means of a push-in connector bridging terminal. The speaker shall include a transformer having multiple taps (0.8W, 1.5W, 3W, 6W at 100V line and 0.4W, 0.8W, 1.5W, 3W at 70V line) adjustable.

The sensitivity at 1W input measured at a distance of 1m shall be 90 dB (330 Hz to 3.3k Hz, pink noise). The speaker shall have a frequency response of 160 to 13k Hz (-20dB) (with fire dome).

The speaker baffle shall be constructed of aluminum. The grille shall be aluminum net. The speaker shall be available in off-white color. The unit shall have dimensions of $\varnothing 180 \times 11$ (exposed section) $\times 110$ (D) mm ($\varnothing 7.09" \times 0.43"$ (exposed section) + 4.33"), and a weight of 1.4 kg (3.09 lb).

The ceiling speaker shall be TOA model PC-1867F.