

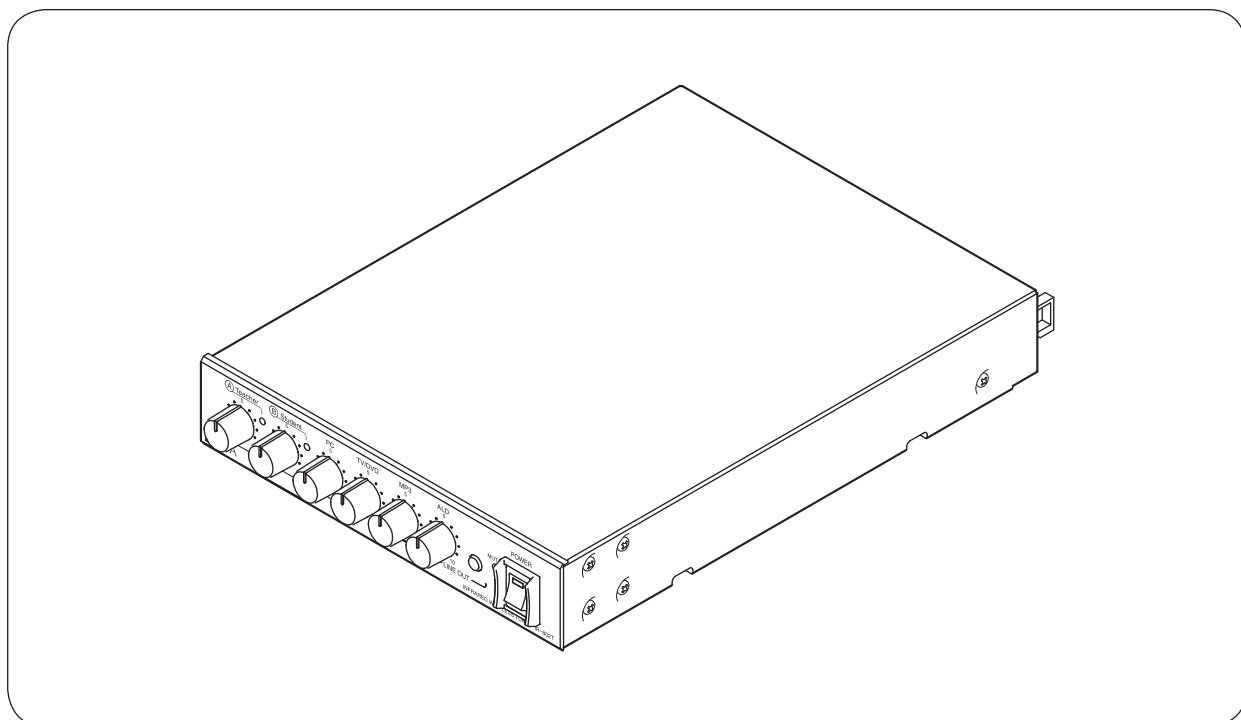

## OPERATING INSTRUCTIONS

# INFRARED WIRELESS TUNER

# IR-802T



This manual offers not only the installation and usage of the IR-802T but also the general descriptions for the entire Wireless microphone system\* such as system configuration and connection. For details about the system components, refer to the instruction manual attached to each component.

\* The Wireless microphone system is comprised of the following components:

- IR-802T Infrared Wireless Tuner
- IR-820SP Infrared Wireless Speaker
- IR-200M and IR-300M Infrared Wireless Microphones
- IR-200BC Battery Charger
- IR-200BT-2 Ni-MH Battery

Thank you for purchasing TOA's Infrared Wireless Tuner.

Please carefully follow the instructions in this manual to ensure long, trouble-free use of your equipment.

TOA Corporation

## TABLE OF CONTENTS

<b>1. IMPORTANT SAFETY INSTRUCTIONS</b> .....	3
<b>2. SAFETY PRECAUTIONS</b> .....	4
<b>3. GENERAL DESCRIPTION</b> .....	6
<b>4. FEATURES</b> .....	6
<b>5. HANDLING PRECAUTIONS</b> .....	6
<b>6. NOMENCLATURE AND FUNCTIONS</b> .....	7
Front .....	7
Rear .....	8
<b>7. SYSTEM CONFIGURATION</b> .....	9
<b>8. OPERATIONS</b> .....	9
8.1. Setting and Adjustment Methods .....	9
8.1.1. Infrared wireless microphone setting .....	9
8.1.2. Sound quality adjustment .....	10
8.2. Operation .....	11
8.2.1. When making microphone announcements .....	11
8.2.2. When broadcasting audio signals from the external equipment .....	12
8.2.3. When using an Assistive listening device .....	12
<b>9. CONNECTIONS</b> .....	13
<b>10. WHEN MOUNTING IN A RACK</b> .....	14
<b>11. VOLUME CONTROL COVER</b> .....	14
<b>12. TROUBLESHOOTING</b> .....	15
<b>13. SPECIFICATIONS</b> .....	16
Accessories .....	16
Optional products .....	16

# 1. IMPORTANT SAFETY INSTRUCTIONS

- Read these instructions.
- Keep these instructions.
- Heed all warnings.
- Follow all instructions.
- Do not use this apparatus near water.
- Clean only with dry cloth.
- Do not block any ventilation openings. Install in accordance with the manufacture's instructions.
- Do not install near any heat sources such as radiators, heat registers, stoves, or other apparatus (including amplifiers) that produce heat.
- Do not defeat the safety purpose of the polarized or grounding-type plug.  
A polarized plug has two blades with one wider than the other. A grounding type plug has two blades and a third grounding prong. The wide blade or the third prong are provided for your safety.  
If the provided plug does not fit into your outlet, consult an electrician for replacement of the obsolete outlet.
- Protect the power cord from being walked on or pinched particularly at plugs, convenience receptacles, and the point where they exit from the apparatus.
- Only use attachments/accessories specified by the manufacturer.
- Use only with the cart, stand, tripod, bracket, or table specified by the manufacturer, or sold with the apparatus.  
When a cart is used, use caution when moving the cart/apparatus combination to avoid injury from tip-over.
- Unplug this apparatus during lightning storms or when unused for long periods of time.
- Refer all servicing to qualified service personnel. Servicing is required when the apparatus has been damaged in any way, such as power-supply cord or plug is damaged, liquid has been spilled or objects have fallen into the apparatus, the apparatus has been exposed to rain or moisture, does not operate normally, or has been dropped.



## 2. SAFETY PRECAUTIONS

**These precautions apply only to the IR-802T Infrared Wireless Tuner.  
For precautions regarding other infrared microphone system devices, please refer to the instruction manual included with each device.**

- Before installation or use, be sure to carefully read all the instructions in this section for correct and safe operation.
- Be sure to follow all the precautionary instructions in this section, which contain important warnings and/or cautions regarding safety.
- After reading, keep this manual handy for future reference.

### Safety Symbol and Message Conventions

Safety symbols and messages described below are used in this manual to prevent bodily injury and property damage which could result from mishandling. Before operating your product, read this manual first and understand the safety symbols and messages so you are thoroughly aware of the potential safety hazards.



**WARNING**

Indicates a potentially hazardous situation which, if mishandled, could result in death or serious personal injury.



**CAUTION**

Indicates a potentially hazardous situation which, if mishandled, could result in moderate or minor personal injury, and/or property damage.



**WARNING**

#### When Installing the Unit

- Do not expose the unit to rain or an environment where it may be splashed by water or other liquids, as doing so may result in fire or electric shock.
- Use the unit only with the voltage specified on the unit. Using a voltage higher than that which is specified may result in fire or electric shock.
- Do not cut, kink, otherwise damage nor modify the power supply cord. In addition, avoid using the power cord in close proximity to heaters, and never place heavy objects -- including the unit itself -- on the power cord, as doing so may result in fire or electric shock.
- Avoid installing or mounting the unit in unstable locations, such as on a rickety table or a slanted surface. Doing so may result in the unit falling down and causing personal injury and/or property damage.
- Since the unit is designed for indoor use, do not install it outdoors. If installed outdoors, the aging of parts causes the unit to fall off, resulting in personal injury. Also, when it gets wet with rain, there is a danger of electric shock.
- The apparatus shall be connected to a mains socket outlet with a protective earthing connection.
- L'appareil doit être branché à une prise d'alimentation avec mise à la terre de protection.

#### When the Unit is in Use

- Should the following irregularity be found during use, immediately switch off the power, disconnect the power supply plug from the AC outlet and contact your nearest TOA dealer. Make no further attempt to operate the unit in this condition as this may cause fire or electric shock.
  - If you detect smoke or a strange smell coming from the unit.
  - If water or any metallic object gets into the unit
  - If the unit falls, or the unit case breaks
  - If the power supply cord is damaged (exposure of the core, disconnection, etc.)
  - If it is malfunctioning (no tone sounds.)
- To prevent a fire or electric shock, never open nor remove the unit case as there are high voltage components inside the unit. Refer all servicing to qualified service personnel.
- Do not place cups, bowls, or other containers of liquid or metallic objects on top of the unit. If they accidentally spill into the unit, this may cause a fire or electric shock.
- Do not touch the power supply plug during thunder and lightning, as this may result in electric shock.

## CAUTION

### When Installing the Unit

- Never plug in nor remove the power supply plug with wet hands, as doing so may cause electric shock.
- When unplugging the power supply cord, be sure to grasp the power supply plug; never pull on the cord itself. Operating the unit with a damaged power supply cord may cause a fire or electric shock.
- The socket-outlet shall be installed near the equipment and the plug (disconnecting device) shall be easily accessible.
- When moving the unit, be sure to remove its power supply cord from the wall outlet. Moving the unit with the power cord connected to the outlet may cause damage to the power cord, resulting in fire or electric shock. When removing the power cord, be sure to hold its plug to pull.
- Avoid installing the unit in humid or dusty locations, in locations exposed to the direct sunlight, near the heaters, or in locations generating sooty smoke or steam as doing otherwise may result in fire or electric shock.
- Avoid touching the unit's sharp metal edge to prevent injury.
- To avoid electric shocks, be sure to switch off the unit's power when connecting the IR-820SP Infrared Wireless Speaker.

- To avoid damage to the unit and/or connected equipment:
  - Never connect the IR-820SP connection terminal to a PC or LAN.
  - Never short-circuit the terminal to ground.
- Be sure to follow the instructions below when rack-mounting the unit. Failure to do so may cause a fire or personal injury.
  - Install the equipment rack on a stable, hard floor. Fix it with anchor bolts or take other arrangements to prevent it from falling down.
  - When connecting the unit's power cord to an AC outlet, use the AC outlet with current capacity allowable to the unit.
  - Rack-mounting screws are not supplied with the unit. Prepare them that are appropriate for the equipment rack.

### When the Unit is in Use

- Make sure that all volume controls are set to minimum position before power is switched on. Loud noise produced at high volume when power is switched on can impair hearing.
- Use the specified AC adapter for the unit. Note that the use of other adapter may cause a fire.
- If dust accumulates on the power supply plug or in the wall AC outlet, a fire may result. Clean it periodically. In addition, insert the plug in the wall outlet securely.
- Switch off the power, and unplug the power supply plug from the AC outlet for safety purposes when cleaning or leaving the unit unused for 10 days or more. Doing otherwise may cause a fire or electric shock.

## FCC Compliance

This device complies with Part 15 of the FCC Rules. Operation is subject to the following two conditions:  
(1) this device may not cause harmful interference, and  
(2) this device must accept any interference received, including interference that may cause undesired operation.  
Any modifications made to this device that are not approved by TOA Corporation may void the authority granted the user by the FCC to operate this equipment.

**Note:** This equipment has been tested and found to comply with the limits for a Class B digital device, pursuant to Part 15 of the FCC Rules. These limits are designed to provide reasonable protection against harmful interference in a residential installation. This equipment generates, uses and can radiate radio frequency energy and, if not installed and used in accordance with the instructions, may cause harmful interference with radio communications. However, there is no guarantee that interference will not occur in a particular installation. If this equipment does cause harmful interference to radio or television reception, which can be determined by turning the equipment off and on, the user is encouraged to try to correct the interference by one or more of the following measures:

- Reorient or relocate the receiving antenna.
- Increase the separation between the equipment and the receiver.
- Connect the equipment into an outlet on a circuit different from that to which the receiver is connected.
- Consult the dealer or an experienced radio/television technician for help.

### 3. GENERAL DESCRIPTION

The Infrared Wireless Microphone System using this IR-802T is a PA system designed for use in the school classrooms assuming that their size is about 10 m x 10 m (30 ft x 30 ft).

The IR-802T is a 2-channel Infrared Wireless Tuner employing a fixed frequency system with 3 AUX inputs. It is combined with an infrared wireless microphone and an infrared wireless speaker to make up the infrared wireless microphone system.

The infrared wireless microphone system eliminates problems with interference or eavesdropping, allowing simultaneous use in adjacent school classrooms.

### 4. FEATURES

- Connected to the IR-820SP Infrared wireless speaker (with a built-in infrared receiver) using a single Category 5 straight through cable fitted with an RJ-45 connector, the IR-802T receives infrared signals and sends mixed audio signals through the cable.
- 3 AUX inputs for PC, TV/DVD, and MP3 audio player.
- The IR-802T's output can be muted by telephone paging input signals.
- Equalizer control knobs for low-, middle-, and high-frequency outputs.
- Mixing output terminal for the ALD (Assistive Listening Device).
- Operated on 24 V DC using the supplied AC adapter (UL/cUL approved product).
- Frequency response optimized to reduce occurrence of acoustic feedback in a classroom whose typical size is about 10 m x 10 m (30 ft x 30 ft).

### 5. HANDLING PRECAUTIONS

- The supplied power supply cord is designed for exclusive use with the IR-802T. Never use it with other equipment.
- Install the IR-802T as far as possible from fluorescent lights, digital equipment, PCs and other devices that generate high-frequency noise.
- The Infrared Wireless Microphone System prevents transmitted contents from being revealed to people outside walls or other shields. However, since transmissions may be eavesdropped by malicious third parties, it is strongly suggested that the user take responsibility for carrying out measures to prevent eavesdropping. TOA assumes no responsibility for any damages that may be sustained without taking appropriate protective measures against eavesdropping.
- When cleaning, be sure to first switch off the tuner's power, then wipe with a dry cloth. If the tuner is extremely dirty, use a cloth moistened in a neutral detergent. Do not use benzene, thinner, alcohol and chemically-processed towels, as they can cause damage to the tuner's components and parts.

## 6. NOMENCLATURE AND FUNCTIONS

[Front]

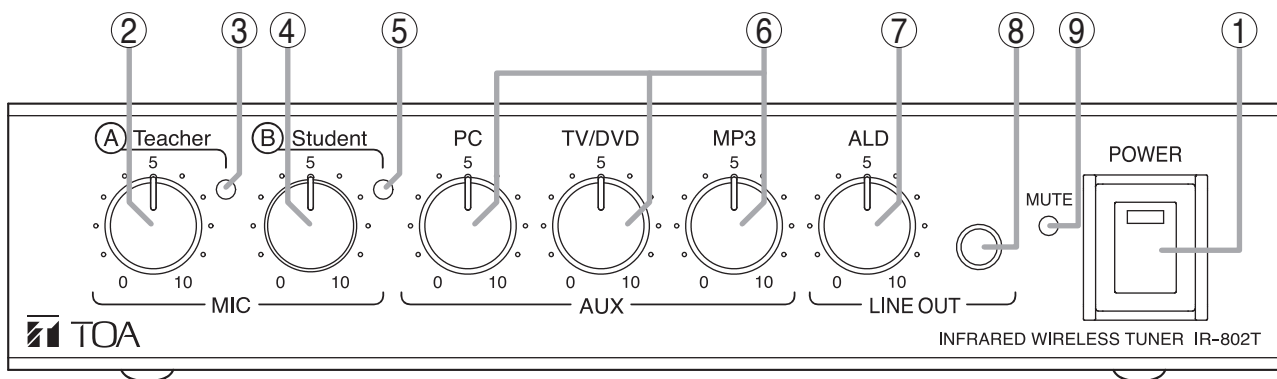

### 1. Power switch/indicator

To turn on the power, set this switch to the ON position, causing the power indicator to light. To turn off the power, set this switch back to the OFF position.

### 2. Teacher's microphone volume control

Adjusts the sound volume of the Teacher's infrared wireless microphone (to be set for Channel A). Rotate the knob clockwise to increase and counterclockwise to decrease the volume.

### 3. Reception indicator (Channel A)

Lights during reception of the infrared wireless microphone set to Channel A.

### 4. Student's microphone volume control

Adjusts the sound volume of the Student's infrared wireless microphone (to be set for Channel B). Rotate the knob clockwise to increase and counterclockwise to decrease the volume.

### 5. Reception indicator (Channel B)

Lights during reception of the infrared wireless microphone set to Channel B.

### 6. Auxiliary input volume controls

Adjust the sound volume of each AUX input for PC, TV/ DVD, and MP3.

Rotate the knob clockwise to increase and counterclockwise to decrease the volume.

### 7. ALD (Assistive Listening Device) output volume control

Adjust the sound volume of the ALD output (8).

Rotate the knob clockwise to increase and counterclockwise to decrease the volume.

### 8. ALD (Assistive Listening Device) output terminal

-10 dB\*, 10 kΩ, unbalanced, monaural mini jack.

Connect this terminal to the amplifier's line input terminal for the assistive listening system.

### 9. Mute indicator

Lights when the rear-mounted Mute input terminal (12) receives a telephone paging call from a school intercom system or other paging equipment, muting the infrared wireless microphone system.

\* 0 dB = 1 V

**[Rear]**

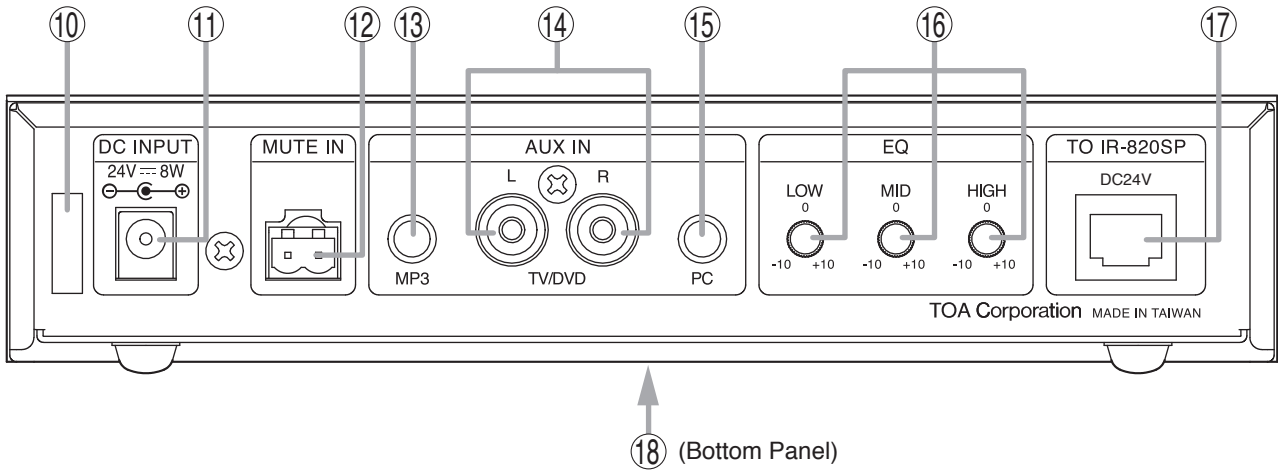

**10. Cable clip**

Run the AC adapter cable through this clip to prevent its plug from being removed.

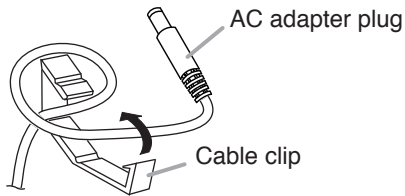

**11. DC inlet terminal**

Connect the supplied AC adapter.

**12. Mute input terminal**

Mutes the infrared microphone system when 25 V line signal from the telephone paging comes in.

**13. MP3 input terminal**

-10 dB\*, 10 kΩ, unbalanced, stereo mini jack.  
Accepts MP3 player output signals.

**14. TV/DVD input terminal**

-10 dB\*, 10 kΩ, unbalanced, RCA jacks.  
Accepts TV or DVD output signals.

**15. PC input terminal**

-10 dB\*, 10 kΩ, unbalanced, stereo mini jack.  
Accepts PC audio output signals.

**16. Equalizer controls**

Adjust low (bass), middle, and high (treble) frequency response.

Rotate each knob clockwise to increase and counterclockwise to decrease low, middle, or high frequency output.

**17. IR-820SP connection terminal**

Connect this terminal to the IR-820SP Infrared Wireless Speaker using a Category 5 cable (straight type).

**Notes**

- Use a Category 5 plenum cable (straight type) when routing the cable in locations where plenum-rated cable is required.
- Cross type cables cannot be used.

**CAUTION**

To avoid damage to this tuner and/or connected equipment:

- Never connect this terminal to a PC or LAN.
- Never short-circuit this terminal to ground.

**18. Marking Plate**

Shows the Manufacturer's name, Model name, and Electrical rating.

\* 0 dB = 1 V



## 7. SYSTEM CONFIGURATION

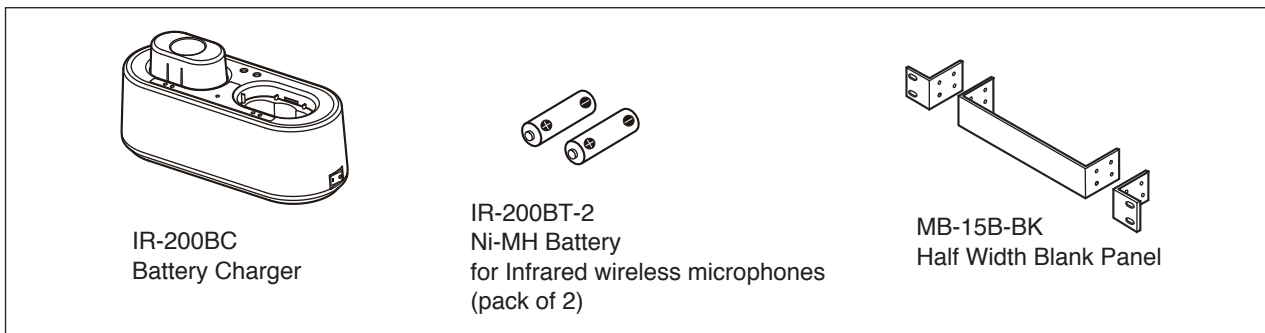
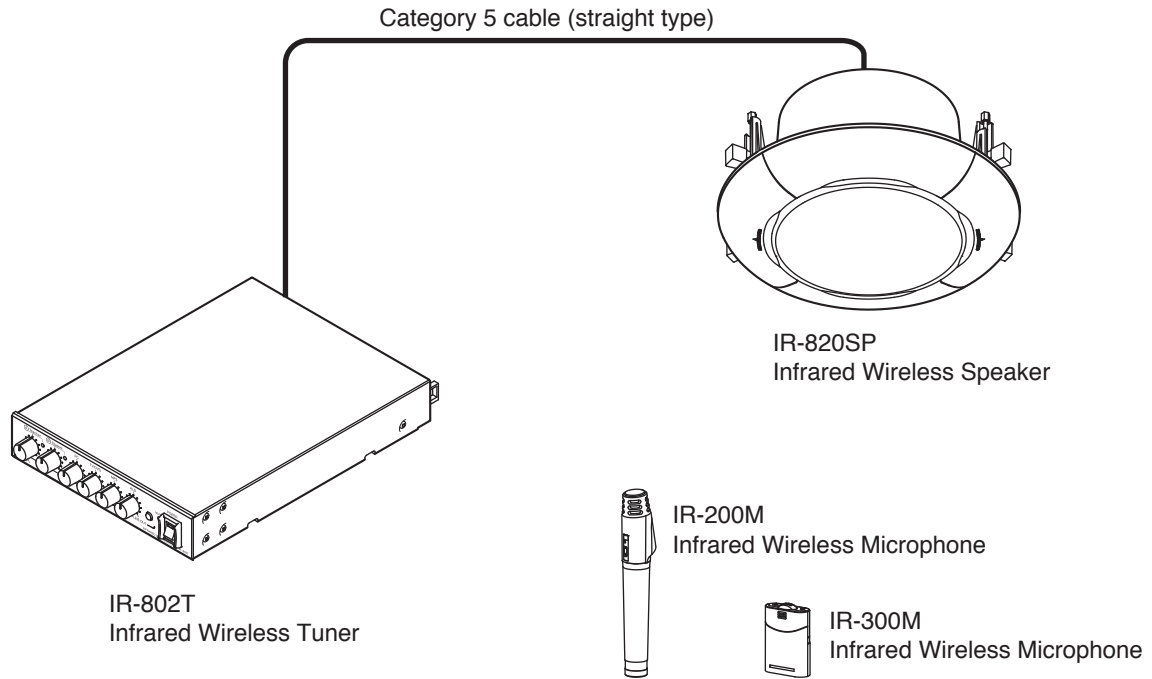

## 8. OPERATIONS

### 8.1. Setting and Adjustment Methods

#### 8.1.1. Infrared wireless microphone setting

Set the channel selector switch of the Teacher's Infrared wireless microphone to Channel A and that of the Student's Infrared wireless microphone to Channel B.

[IR-300M]

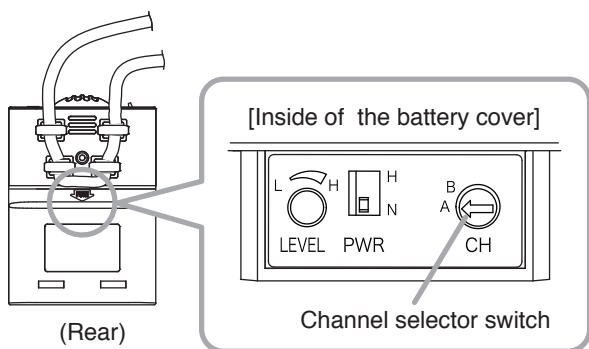

[IR-200M]

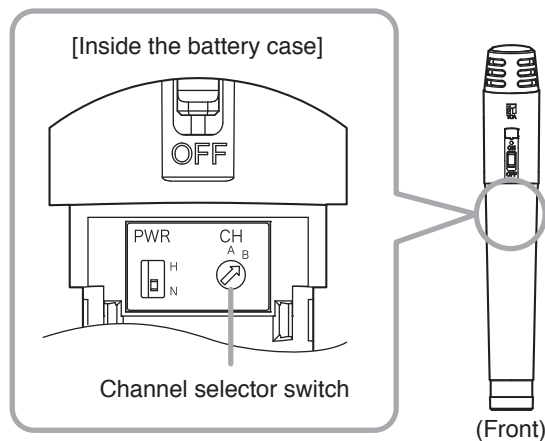

#### Note

For details about the setting method, refer to the instruction manual supplied with the infrared wireless microphone.

### 8.1.2. Sound quality adjustment

Adjust the sound quality when installing the IR-802T.

The example here shows the procedure to adjust the sound quality of the IR-802T using the infrared wireless microphone.

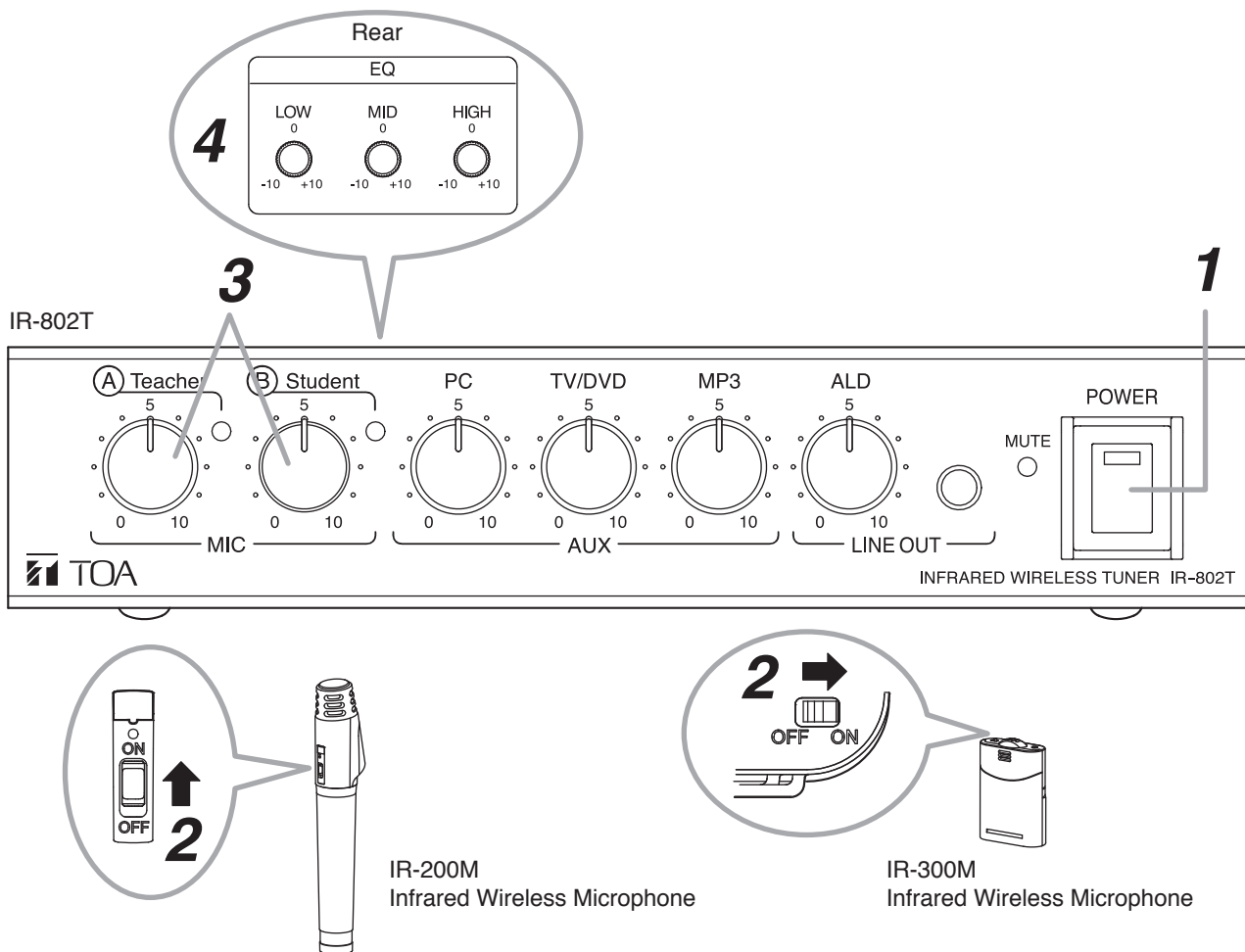

**Step 1.** Turn on the unit's power switch.  
The power indicator lights.

**Step 2.** Turn on the infrared wireless microphone's power switch.  
The reception indicator lights for the channel receiving a signal.

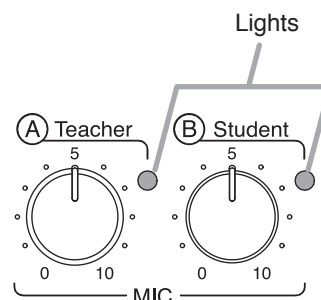

**Step 3.** Adjust the volume control knob for an appropriate output sound.

**Note**

Output signal distortion is more likely to increase when the volume control knob is set beyond the "7" position.

**Step 4.** Adjust the equalizer controls for an appropriate sound quality.  
Each of low-, middle-, and high-frequency outputs can be individually adjusted.

**Notes**

- Sound quality of the infrared wireless microphones and each audio signal input to the AUX terminals cannot be individually adjusted.
- Acoustic feedback tends to occur when the MID level is set relatively high.

## 8.2. Operation

### 8.2.1. When making microphone announcements

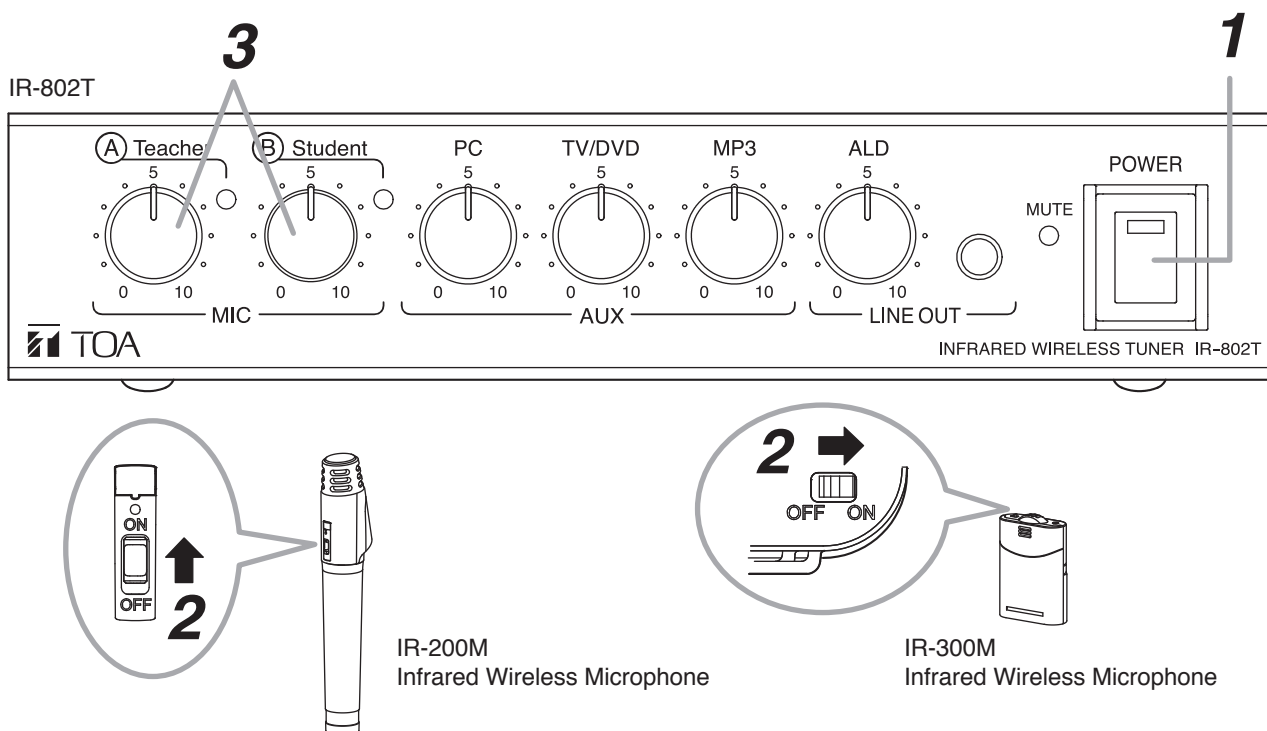

**Step 1.** Turn on the unit's power switch.  
The power indicator lights.

**Step 2.** Turn on the infrared wireless microphone's power switch.  
The reception indicator lights for the channel receiving a signal.

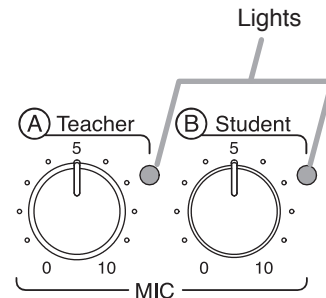

**Step 3.** Adjust the volume control knob for an appropriate output sound.

#### Notes

- Output signal distortion is more likely to increase when the volume control knob is set beyond the "7" position.
- When a telephone paging call from a school intercom system or other paging equipment enters the unit, the Mute indicator lights and the current broadcast being made from the unit is muted.
- Do not cover the microphone head with your hand(s), as doing so may cause acoustic feedback\* to occur.

\* A phenomenon that squealing will occur when sound from the speakers enters the microphone, is then re-amplified, and output through the speakers, forming a feedback loop.

### 8.2.2. When broadcasting audio signals from the external equipment

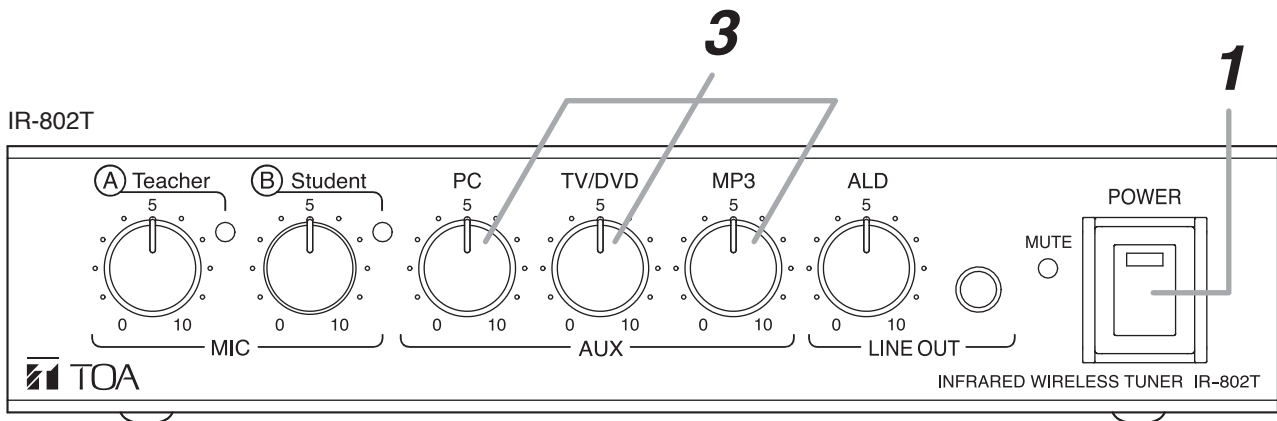

**Step 1.** Turn on the unit's power switch.  
The power indicator lights.

**Step 2.** Turn on the external equipment's power switch, then reproduce audio signals.

**Step 3.** Adjust the corresponding Auxiliary input volume control for an appropriate output sound.

#### Notes

- Adjust each input volume control knob depending on the audio signal input level from the external equipment.
- When a telephone paging call from a school intercom system or other paging equipment enters the unit, the Mute indicator lights and the current broadcast being made from the unit is muted.

### 8.2.3. When using an Assistive listening device

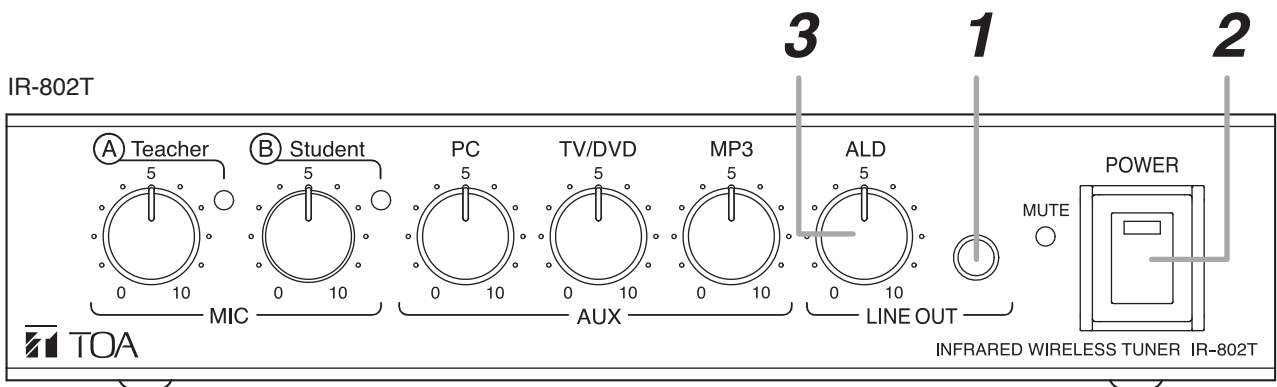

**Step 1.** Connect the Assistive listening system to the ALD output terminal on the front panel.

**Step 2.** Turn on the unit's power switch.  
The power indicator lights.

**Step 3.** Adjust the ALD output volume control for an appropriate output sound.

#### Note

When a telephone paging call from a school intercom system or other paging equipment enters the unit, the Mute indicator lights and the current broadcast being made from the unit is muted.

## 9. CONNECTIONS

### CAUTION

- To avoid electrical shocks, be sure to switch off the IR-802T's power when connecting the IR-820SP.
- To avoid damage to the IR-802T and/or connected equipment:
  - Never connect the "TO IR-820SP" terminal to a PC or LAN.
  - Never short-circuit this terminal to ground.

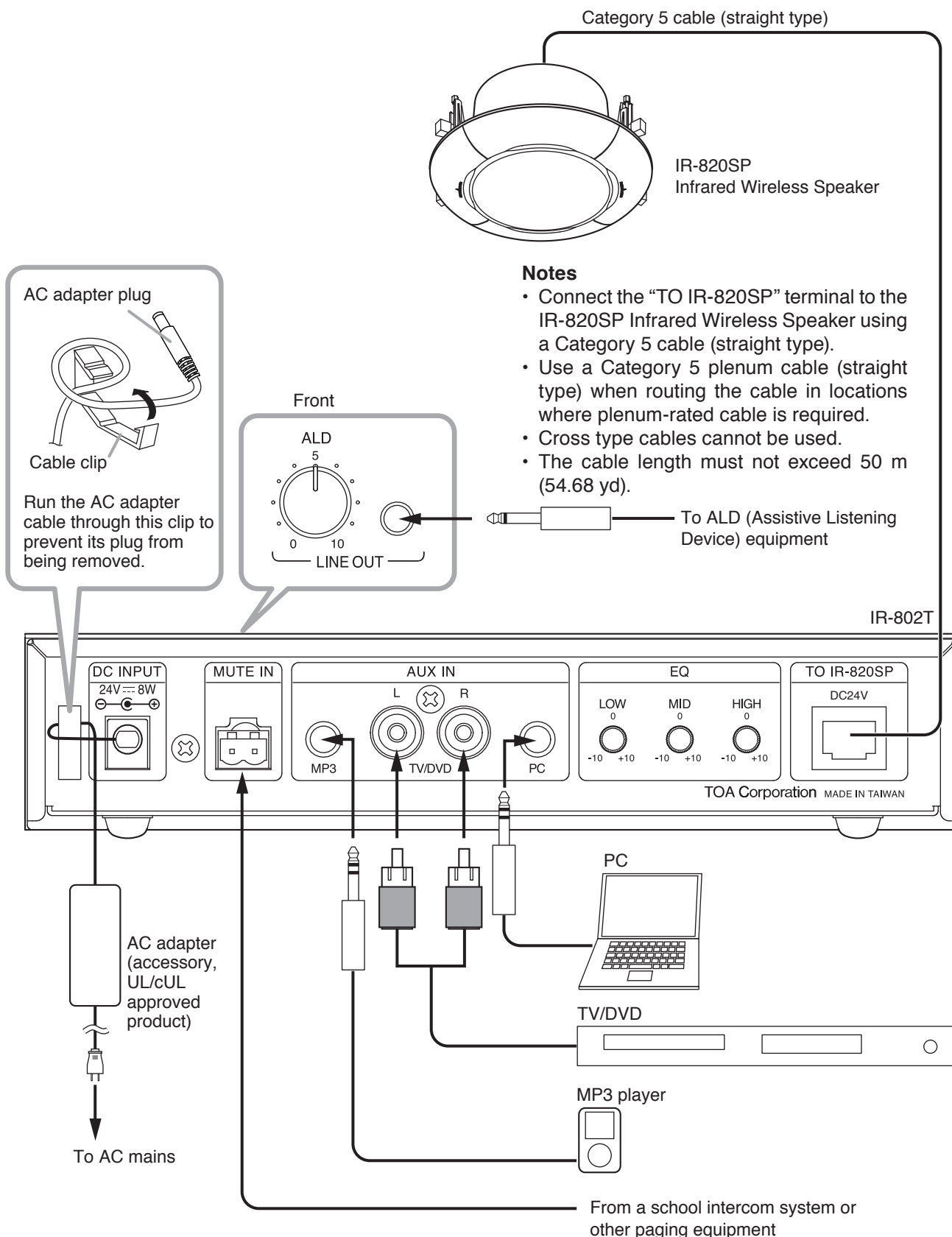

## 10. WHEN MOUNTING IN A RACK

Use the optional MB-15B-BK Half Width Blank Panel when installing the unit in a 19" rack (1 unit size.) The MB-15B-BK consists of all the rack-mounting parts such as brackets and screws as shown below. Be sure to remove the rubber feet located on the unit's bottom surface before mounting.

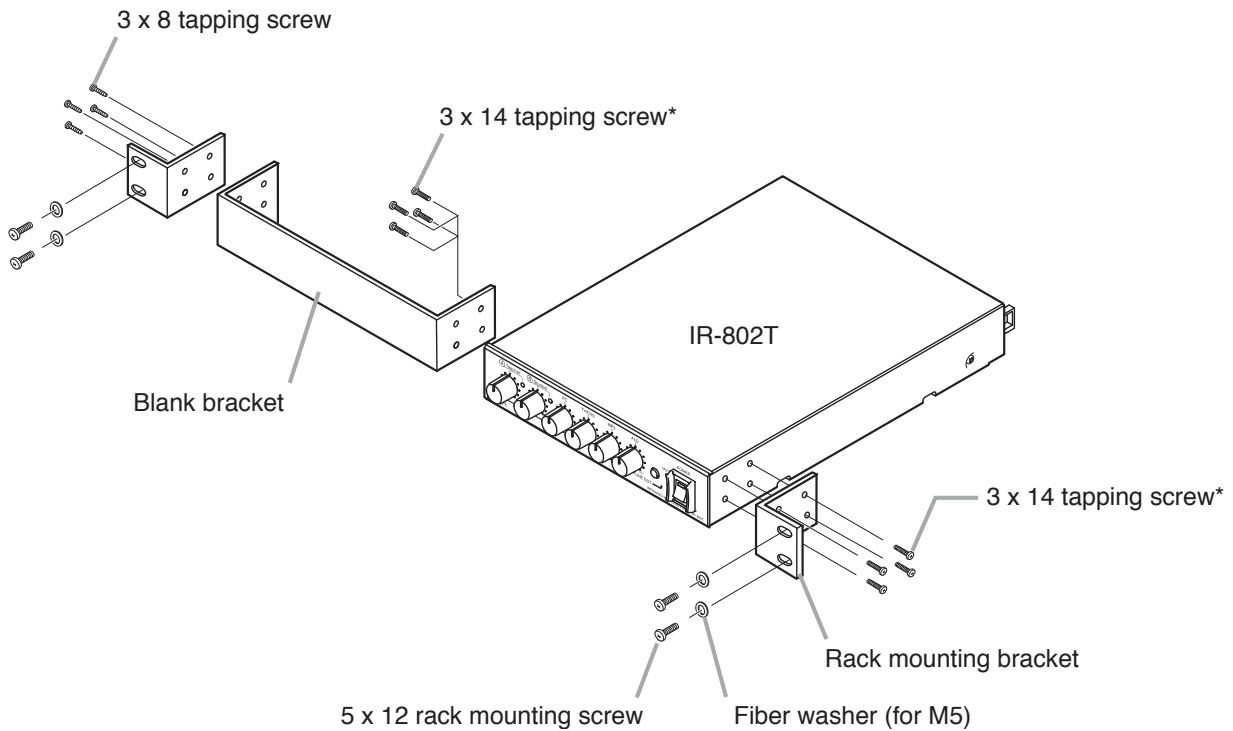

\* Secure the brackets with the screws supplied with the MB-15B-BK after removing the case holding screws, which are no longer used.

## 11. VOLUME CONTROL COVER

To prevent the accidental change of the setting of the volume controls, remove the knobs after setting them to the desired position and attach the optional cover instead.

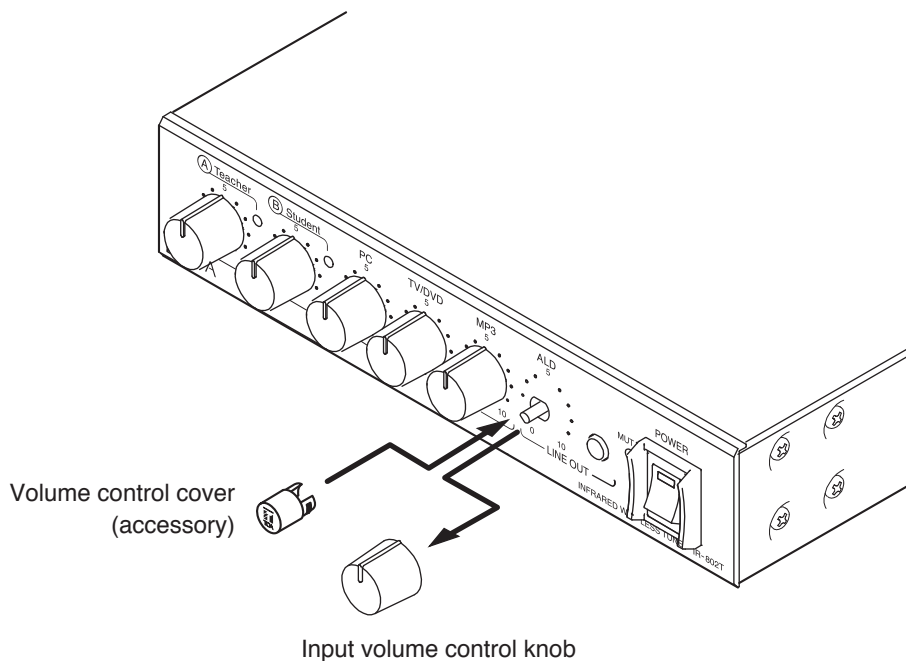

## 12. TROUBLESHOOTING

Symptom	Cause and Points to Check	Remedy
The power indicator does not light when the power switch is turned on.	Power plug is unplugged from an AC mains outlet.	Plug the power plug into an AC wall outlet.
The power indicator flashes.	The connection cable to IR-820SP is possibly failed.	Confirm correctness of the connection to IR-820SP and connection cable. If faulty is found, connect correctly or replace the cable with appropriate one.
No signal received.	Infrared wireless microphone's power switch is not set to ON.	Set the microphone's power switch to ON.
	Infrared wireless microphone's battery has become discharged.	Replace the battery with a new one. If a rechargeable battery is used, recharge it.
	The microphones' channels are incorrectly set as follows: Teacher's microphone: Channel B Student's microphone: Channel A	Set the microphones' channels as follows: Teacher's microphone: Channel A Student's microphone: Channel B
No sound outputs.	IR-802T is not connected to IR-820SP properly.	Confirm correctness of the connection to IR-820SP and connection cable. If faulty is found, connect correctly or replace the cable with appropriate one.
	External equipment is not connected to IR-802T properly.	Connect correctly.
Sound is too faint to hear.	IR-802T's volume control is set to too low a level.	Set the IR-802T's volume control to an appropriate volume level.
	The volume control of the external equipment is set to too low a level.	Set the volume control of the external equipment to an appropriate volume level.
Noise or strange (i.e. muddy) sound is heard.	IR-820SP is installed in close proximity to a device generating radio noise or infrared light.	Install IR-820SP properly, referring to "Installation precautions" for the infrared wireless speaker.
	Teacher's microphone and student's microphone are set at the same channel.	Set the microphones' channels as follows: Teacher's microphone: Channel A Student's microphone: Channel B
Short transmission distance.	IR-820SP is not properly installed.	Install IR-820SP properly.
Microphone's volume controls are not adjustable.	The microphones' channels are incorrectly set as follows: Teacher's microphone: Channel B Student's microphone: Channel A	Set the microphones' channels as follows: Teacher's microphone: Channel A Student's microphone: Channel B
Acoustic feedback occurs.	The microphone head is covered with your hand(s).	Do not cover the microphone head with your hand(s).
	The MID level of the equalizer controls is set relatively high.	Decrease the MID level of the equalizer controls.

## 13. SPECIFICATIONS

Version	CE-GB	CU
Power Source	230 V AC, 50/60 Hz (supplied AC adapter must be used)	120 V AC, 50/60 Hz (supplied AC adapter must be used)
Power Consumption	8 W (based on UL standards) Max. 40.8 W (rated output at IR-820SP)	
Receiving Frequency	Teacher (Channel A): 3.100 MHz Student (Channel B ): 3.350 MHz	
Receiver Sensitivity	50 dB or more, Signal to Noise ratio (40 dB $\mu$ V input, 1 kHz modulation, $\pm$ 4.8 kHz deviation)	
Signal to Noise Ratio	Tuner: 60 dB or more (60 dB $\mu$ V input, 1 kHz modulation, $\pm$ 4.8 kHz deviation, A-weighted, Equalization: Centered) AUX: 75 dB or more (A-weighted, Equalization: Centered)	
Tone Squelch Frequency	32.768 kHz	
Input	AUX PC: line, -10 dB*, 10 k $\Omega$ , unbalanced, stereo mini jack (internal mixing) AUX DVD/TV: line, -10 dB*, 10 k $\Omega$ , unbalanced, 2P RCA jack (internal mixing) AUX MP3: line, -10 dB*, 10 k $\Omega$ , unbalanced, stereo mini jack (internal mixing) Mute: 25 V line signals of telephone paging from a school intercom system	
Output	ALD (Assistive Listening Device): line, -10 dB*, 10 k $\Omega$ , unbalanced, monaural mini jack Speaker: RJ45 (dedicated terminal for IR-820SP connection)	
Equalization	High: $\pm$ 10 dB at 10 kHz Mid: $\pm$ 10 dB at 1.3 kHz Low: $\pm$ 10 dB at 100 Hz	
Mute Function	Muted by 25 V line signals	
LED Indicator	Power (green) x 1, Infrared reception (yellow) x 2, Mute (red) x 1	
Operating Temperature	-10 to +50 °C (14 to 122 °F)	
Operating Humidity	90 %RH or less (no condensation)	
Finish	Panel: Aluminium, black Case: Steel plate, black	
Dimensions	210 (w) x 46 (h) x 312 (d) mm (8.27" x 1.81" x 12.28")	
Weight	1.8 kg (3.97 lb)	

\* 0 dB = 1 V

**Note:** The design and specifications are subject to change without notice for improvement.

### • Accessories

AC adapter (UL/cUL approved product, DC cord length: 1.8 m or 5.91 ft) .....	1
AC power cord (2 m or 6.56 ft) .....	1
Volume control cover .....	6
Removable terminal plug (2 pins) .....	1

### • Optional product

MB-15B-BK Half Width Blank Panel

#### Traceability Information for Europe (EMC directive 2004/108/EC)

Manufacturer:  
TOA Corporation  
7-2-1, Minatojima-Nakamachi, Chuo-ku, Kobe, Hyogo, Japan

Authorized representative:  
TOA Electronics Europe GmbH  
Suederstrasse 282, 20537 Hamburg, Germany



TOA Corporation

URL: <http://www.toa.jp/>

133-07-00014-00