

## DESCRIPTION

The F-1000 Series Speaker are compact two-way speaker systems designed for high efficiency, wide range, and high power input handling capability. These speaker systems can be installed in a manner ideal for the location and intended application.

## SPECIFICATIONS

Enclosure	Bass-reflex type
Rated Input	15 W (high impedance)
Power Handling Capacity	Continuos pink noise: 30 W (low impedance) Continuos program: 90 W (low impedance)
Rated Impedance	8 Ω 100 V line: 670 Ω (15 W), 2 kΩ (5 W), 3.3 kΩ (3 W), 10 kΩ (1 W) 70 V line: 330 Ω (15 W), 670 Ω (7.5 W), 2 kΩ (2.5 W), 3.3 kΩ (1.5 W), 10 kΩ (0.5 W)
Sensitivity	87 dB (1 W, 1 m) at installation in 1/2 free sound field
Frequency Response	85 Hz - 20 kHz, -10 dB at installation in 1/2 free sound field
Crossover Frequency	5 kHz
Directivity Angle	Horizontal: 90°, Vertical: 90°
Speaker Component	Low frequency: 10 cm (4") cone-type High frequency: Balanced dome tweeter
Input Terminal	Push-in terminal
Finish	Enclosure: HIPS, black Punched net: Surface-treated steel plate, black, paint Joint bracket, wall bracket: Steel plate, t1.6, black, paint Speaker bracket: Die-cast aluminum, black, paint
Dimensions	130 (W) × 202 (H) × 131 (D) mm (5.12" × 7.95" × 5.16")
Weight	2 kg (4.41 lb) (including the supplied brackets)
Accessory	Speaker bracket...1, Joint bracket...1, Wall bracket...1, Bracket fixing screw...1 set
Option	Board hanger bracket: HY-BH10B, Ceiling mount bracket: HY-CM10B (used for the horizontal speaker mounting), Cluster bracket: HY-CL10B, Speaker stand: ST-16A

Note: Bolts and nuts for mounting the bracket to the wall or ceiling are not included. Prepare them separately.

## APPEARANCE

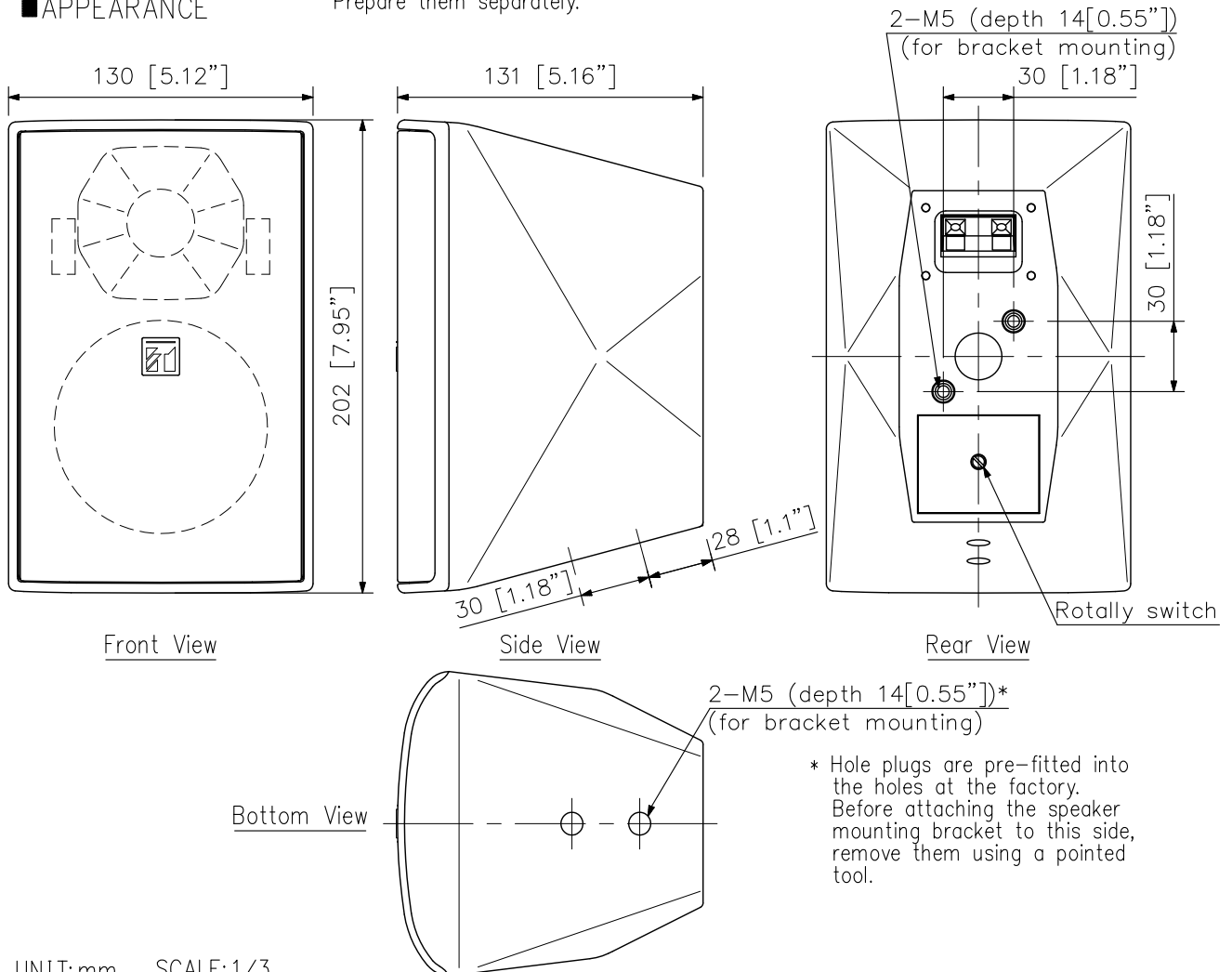

UNIT:mm SCALE:1/3

**■ APPEARANCE**

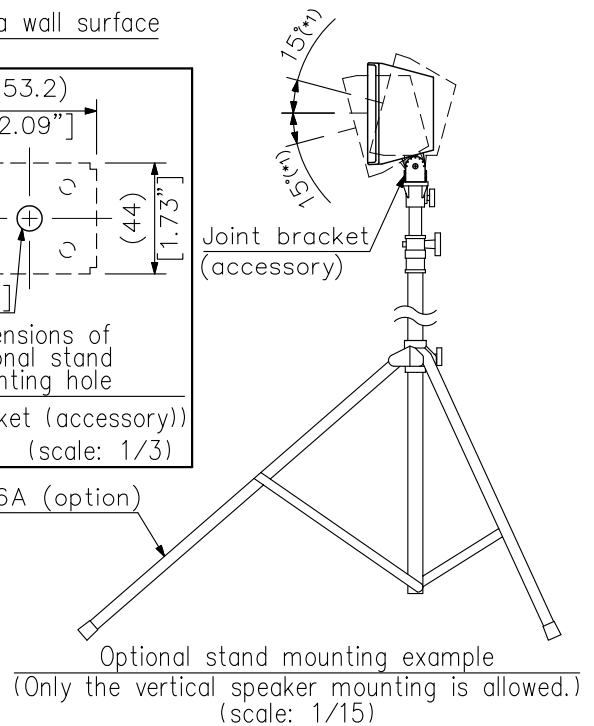
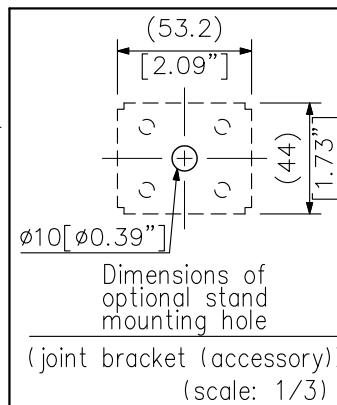
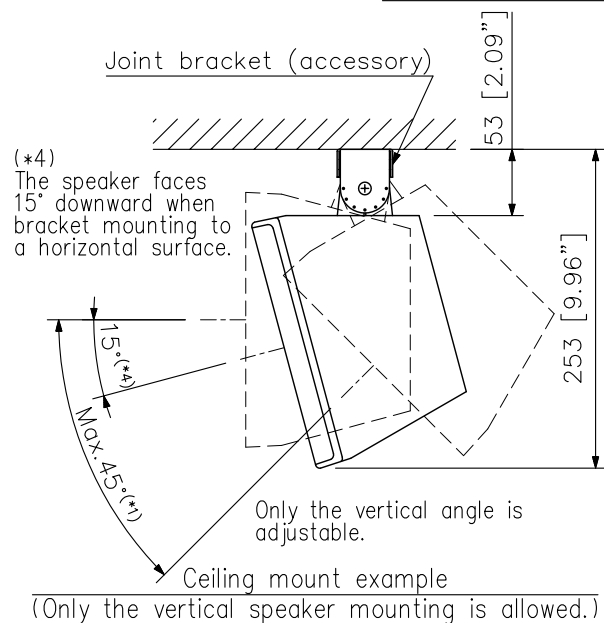
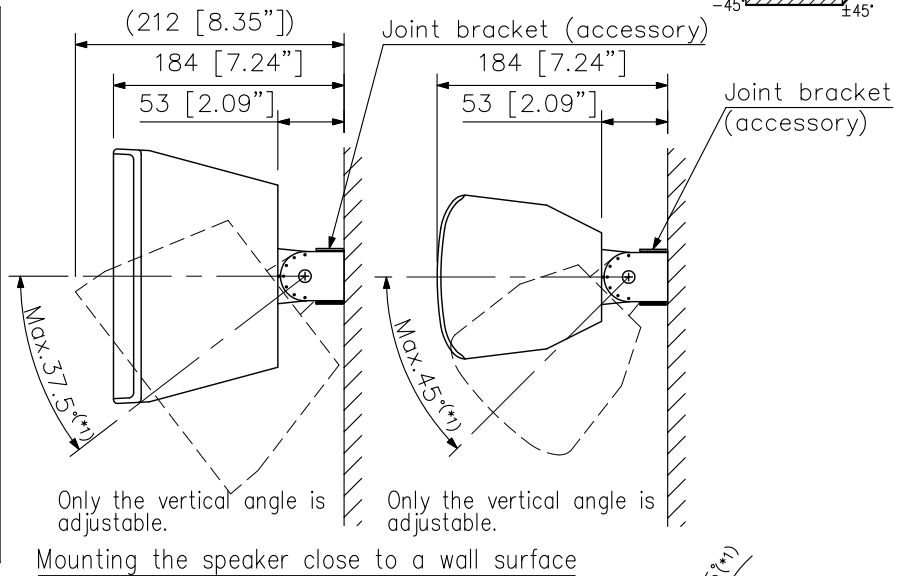
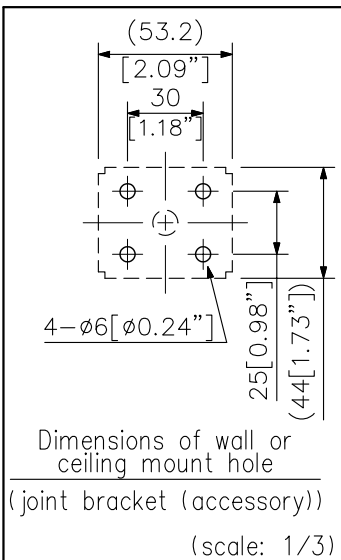
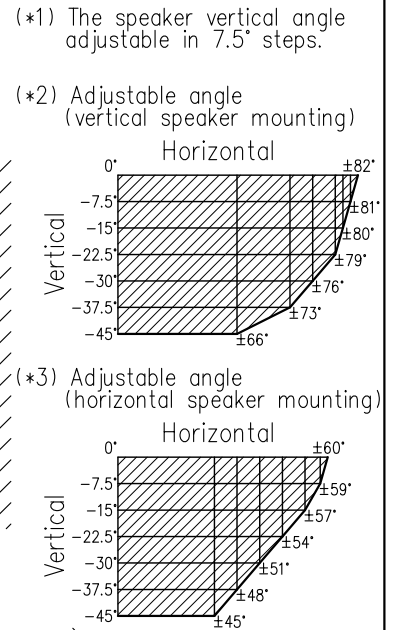
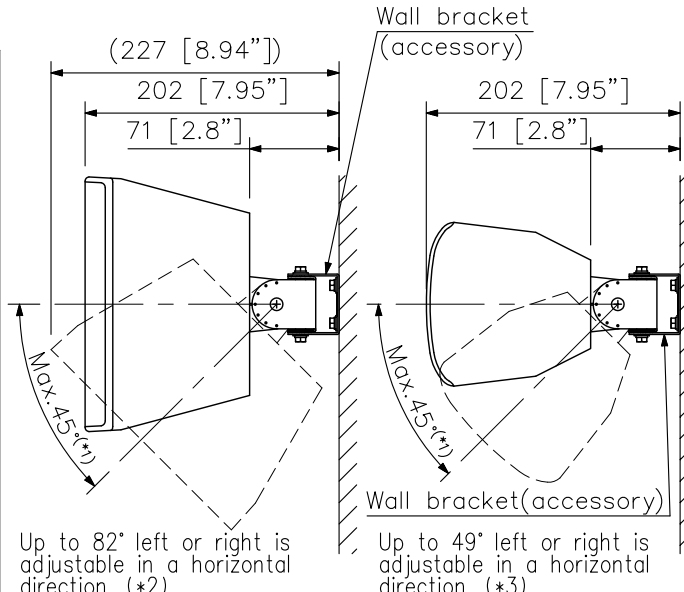
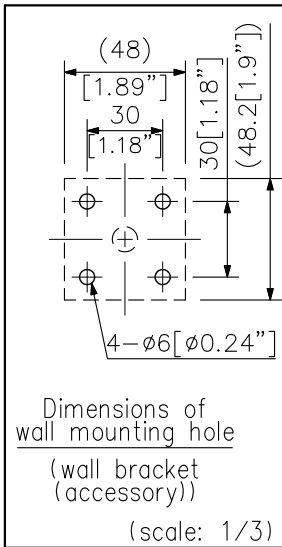

UNIT:mm SCALE:1/6