



UHF WIRELESS SET

S5.3-HC-D2E
S5.3-HC-D2U
S5.3-HC-G2U

DESCRIPTION

The S5.3-HC includes a handheld wireless microphone and a true diversity tuner. Both of them feature user-friendly operability, and employ an easy-to-read LCD display. Also, it is possible to perform the system settings through infrared communications, and monitor the system status using the supplied PC software.

SPECIFICATIONS

Version	D2E/D2U	G2U
Product Composition	Handheld wireless microphone S5.3-HCX *1, Diversity tuner S5.3-RX *1	
Frequency Range	854 - 865 MHz, UHF	606 - 622 MHz, UHF
Channel Selectable	9 banks, 12 frequencies max/bank	
Tone Frequency	32.768 kHz	
Operating Temperature	-10 °C to +50 °C (14 °F to 122 °F)	
Accessory	CD (PC Monitoring Software) *1, BNC cable *2, Microphone holder W3/8" (with stand adapter) *1, Wireless antenna *2, Color ring (6 colors) *6	

Wireless microphone

Microphone Element	Electret Condenser microphone unit: cardioid
Modulation	Frequency modulation
RF Carrier Power	50 mW or less
Tone Frequency	32.768 kHz
Modulation System	PLL synthesized
Maximum Input Level	142 dB SPL (microphone sensitivity: Gain "0")
Maximum Deviation	±40 kHz
Audio Frequency Response	90 Hz - 20 kHz
Dynamic Range	110 dB or more (with S5.3-RX)
Battery	LR6 (AA)
Battery Life	10 hours (alkaline)
Indicator	LCD display, Power lamp
Antenna	Built-in type
Function	Mute switch, Infra-Red link port, Battery life indicator (4 steps), Microphone sensitivity adjustment (Gain 0-2; 12 dB)
Finish	Dark gray
Dimensions	ø50 × 232.9 mm (ø1.97" × 9.17")
Weight	300 g (0.66 lb) (with battery)

Wireless tuner

* 0 dB = 1 V

Power Source	230 V AC, 50 Hz (supplied AC adapter must be used)
Power Consumption	300 mA (13 V DC)
Receiving System	Double super-heterodyne
Diversity System	Space diversity (true diversity)
Audio Output	LINE: -22 dB*/MIC: -62 dB* LINE/MIC selectable, 600 Ω, balanced, XLR-3-32 type connector Headphone: max. 100 mW 16 Ω, unbalanced, phone jack -28 dB*, 600 Ω, unbalanced, phone jack
Antenna Input	50 Ω, BNC
Antenna Phantom Power	9 V DC, 30 mA (max) (Available to turn off phantom power)
Receiving Sensitivity	0 dBμV or less (12 dB SINAD)
Squelch Sensitivity	6 - 36 dBμV variable
Squelch System	Using together of noise SQ, carrier SQ and tone SQ
Tone Frequency	32.768 kHz
Indicator	LCD, Power lamp, Mute lamp, ANT A/B lamp
Signal to Noise Ratio	110 dB or more (A-weight)
Harmonic Distortion	1 % or less (typical)
Frequency Response	50 Hz - 20 kHz, ±3 dB
Function	Battery indicator (7 steps), Headphone output, Infra-Red link port, Channel scan, Monitoring software with USB connectivity
Finish	Chassis: Steel, dark gray, painting Front panel: Anodized aluminum, silver
Dimensions	210 (W) × 46 (H) × 210 (D) mm (8.27" × 1.81" × 8.27") (excluding antenna)
Weight	1.3 kg (2.87 lb)

■ APPEARANCE

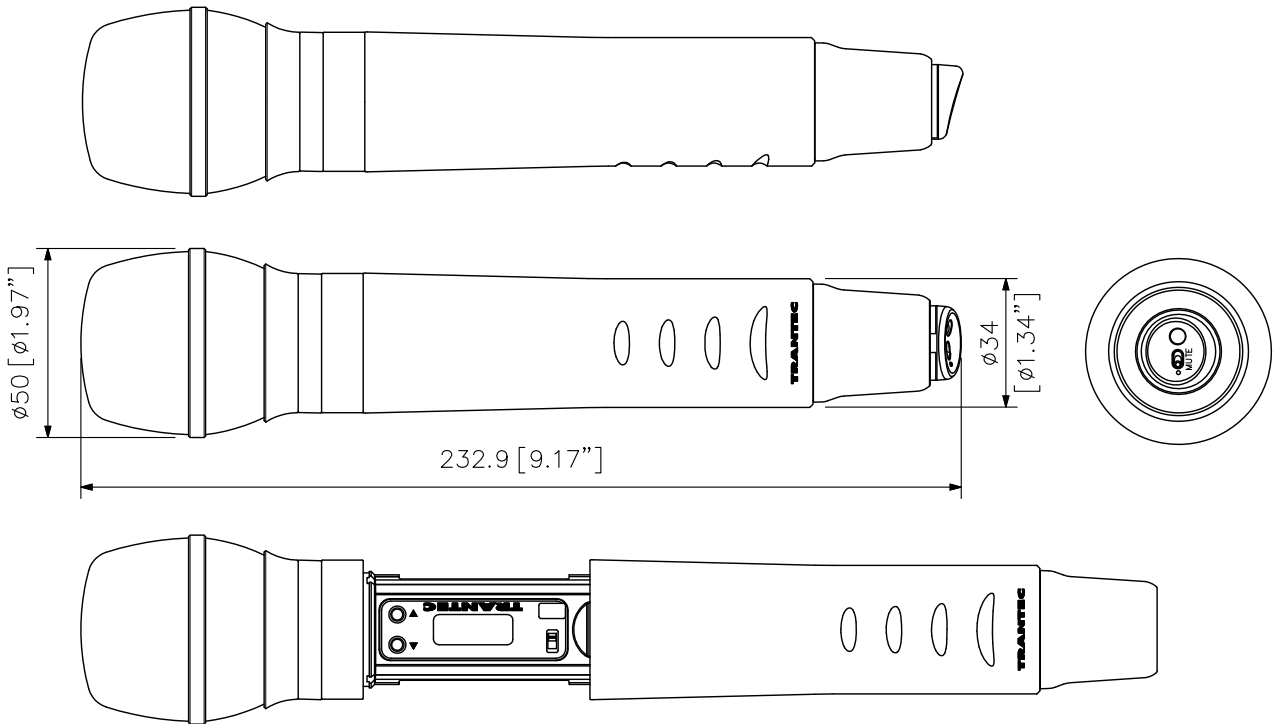

Wireless microphone

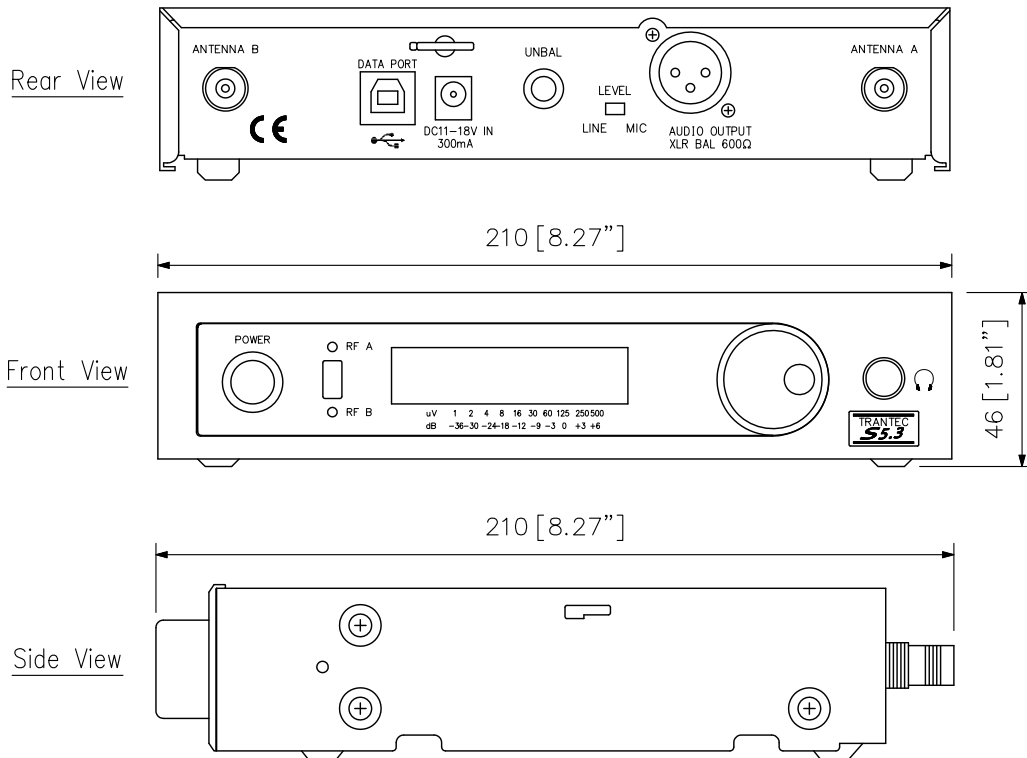

Wireless tuner

UNIT:mm SCALE:1/2